

# Electric Heating Element

## Model #9509

The 9509 heating element is a self-regulating and temperature limiting element for heating applications where minimum operator control is required. The 9509 has an integrated safety thermostat to prevent it from overheating.

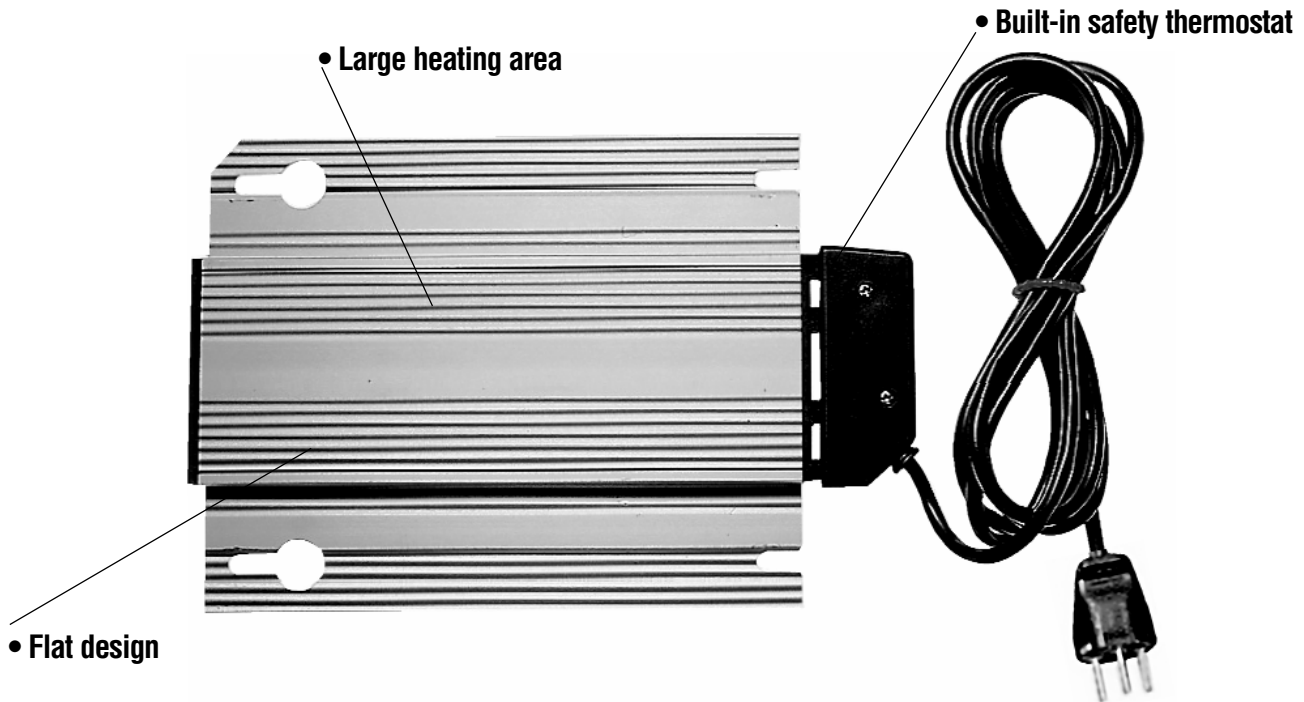

### Technical Data

Part No.	9509	Power cord:	PVC cable, 8 ft with grounded plug
Operating voltage:	AC 100-120V	Protection class:	I (grounded)
Heating power:	600W	Protection type:	IP 54 (protected against water spray)
Operating current:	5A at 120VAC	Weight:	Approx. 2.2 lbs.
Surface temperature:	Approx. 210°C when not mounted	Approvals:	UL, VDE
Heating element:	Micanite heating element	Applications:	Chafing dishes
Overheat protection:	Built-in safety thermostat (temperature-limiting)		
Heater body:	Aluminum profile, silver anodized		
Wire compartment:	Plastic UL94V-0		

### Accessories & Options

For use with all Spring rectangular full-size chafing dishes

*Note: Specifications are subject to change without notice, please refer to website for the latest specifications.  
One-year warranty.*

# Spring USA

# Electric Heating Element Diagram

Model #9509

