



Project: _____
 Item #: _____ Quantity: _____
 Model #: _____



Model AF350
 Downdraft Air
 Filter System

Undercounter Downdraft Air Filter System
**For Induction Use With MAX Induction™ Only*

Model: AF350

This Air Filtration System is designed exclusively for use for built-in installations with induction heat sources and cannot be used as a stand alone device.

Any other use voids the warranty and does not comply with UL standards of operation.

Under no circumstances should this unit be used with other heating devices. To do so can create a fire hazard.

Order Guide:

| Induction Ranges | No. AF350 Filters | Induction Ranges | No. AF350 Filters |
|------------------|-------------------|------------------|-------------------|
| 1 | 1 | 5 | 3 |
| 2 | 1 | 6 | 3 |
| 3 | 2 | 7 | 4 |
| 4 | 2 | 8 | 4 |

Short Form Specification:

Unit to be a Spring USA Model: AF350 Downdraft Air Filter System designed for custom, in-cabinet or under-counter installation (by others) for mobile MAX Induction™ Range(s). Unit has an attractive, counter-level downdraft capture baffle, high efficiency triple filter system, including washable pre-filter, replaceable primary rigid cell filter and carbon filter; plus all the construction and filtration performance features listed.

Construction Features:

- Modular 18-gauge painted enclosure, designed for easy under-counter installation
- Quiet running 350 watt blower
- Drawer slides with stainless steel support tray for easier filter access
- Attractive, flared, stainless steel, counter-level downdraft capture flue with removable stainless steel filter cap
- Removable, galvanized baffle pre-filter [washable]
- High-efficiency, primary rigid-cell filter [replaceable]
- Carbon absorption, ring-panel final filter [replaceable]
- Power On-Off switch with indicator light [lower left]
- Single-point power connection via NEMA 5-15P plug

Air Filtration System Performance:

Blower: Rated at 350 CFM at 5" E.S.P.; 240 CFM at 2" E.S.P.
 Nominal Air Velocity: 3000 FPM at intake hood opening
 Noise Level: 64 dBA at 6', with clean filters
 ASHRAE 52 Capture: 95% Dust Spot Efficiency
 MERV No. 14 Capture: 98.8% of 3-10 micron particles or 96.7% of 1-3 micron particulate

Standard Warranty:

One Year, Parts & Labor (Excluding Filters)
 Agency Listings:
 UL-Sanitation to NSF-4
 ANSI/NSF No. 2
 CETL Approved

Available Options/Accessories:

Stainless countertop trim piece (finishes countertop penetration)
 Replacement High Efficiency Primary Filter (Item # AF98710)
 Replacement Carbon Final Filter (Item # AF98711)
 Replacement Galvanized Baffle Filter (Item # AF9879)

Project: _____
 Item #: _____ Quantity: _____
 Model #: _____

Undercounter Downdraft Air Filter System

For Induction Use Only* **Model: AF350

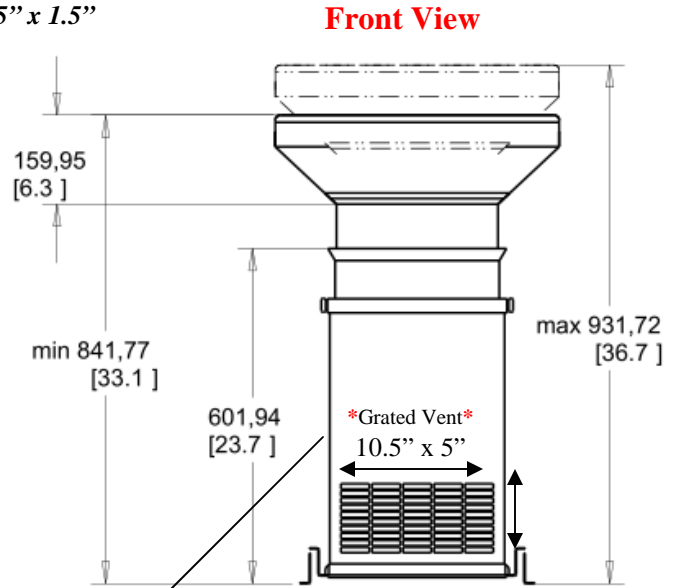
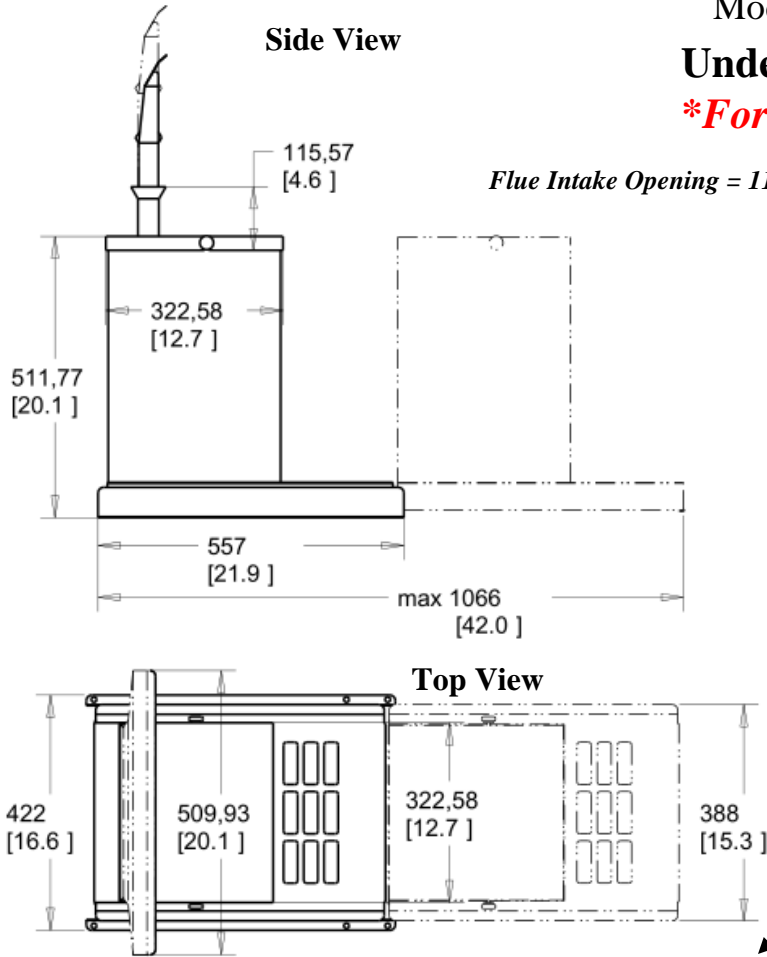

Flue Countertop Cutout
11.65" W x 1.65" D

The opening clearance must be 24" high to allow access to the AF350 Unit. This is needed to pull the unit forward for removal of the cap, enabling access to the filter array for servicing.

A minimum cabinet opening of 55 square inches (or 10.5" x 5") must be made to allow the filtered air to escape from the cabinet cavity.

[EC] Electric Requirements [Each Unit]:

| Model | Voltage | Phase | Hertz | Watts | Amps | Plug* | Receptacle |
|-------|------------|-------|-------|-------|------|------------|------------|
| AF350 | 110-120 AC | 1 | 60 | 350 | 3 | NEMA 5-15P | NEMA 5-15R |

*6' Ft (1.8 m) Power cord with plug provided

Key Dimensions [Without Capture Flue] & Shipping Information:

| Model | Unit Width | Unit Depth | Unit Height Including Drawer Slide* | Shipping Weight | Shipping Carton | | |
|-------|---------------------|---------------------|---|------------------------|-----------------|-----------------|-----------------|
| | | | | | Length | Width | Height |
| AF350 | 12.375" (315 mm) | 12.375" (315 mm) | 36.7" maximum (931.72 mm) | 45 Pounds (20.4 kg) | 25" (635 mm) | 25" (635 mm) | 25" (635 mm) |

*Top of air filter flue intake extends 6.3" (159.95 mm) above the work top, when installed

Notes & Conditions of Use:

- For use with induction heat source(s) only.
- Filter System must be installed in base cabinet or display cooking pedestal by a qualified contractor.



Due to continuous product improvement, specifications are subject to change without notice.