



Project: \_\_\_\_\_

Item #: \_\_\_\_\_ Quantity: \_\_\_\_\_

Model #: \_\_\_\_\_



## Built-In Induction Range

### Order Guide:

Model #	Voltage	Peak Power	Plug Type
SM-181R	110-120	1800 Watts	NEMA 5-15 6' Cord
SM-261R	208-240	2600 Watts	NEMA 6-20 6' Cord
SM-263R	220-240	2600 Watts	CEE 7/7 16 A Schuko Plug 1.8 m Cord
SM-263RU	220-240	2600 Watts	BS 1363 13A U.K. Plug 1.8 m Cord

### Short Form Specification:

Unit to be a Spring USA **MAX Induction™** SM-\_\_\_\_\_(Specify 181, 261 or 263) Model, Built-In, Flush Mountable Induction Heating Unit, with installation-ready modular flanged base and 5 mm thick tempered glass hot top, with (optional) mounting frame bracket; and separate control panel with 43" (1.1 m) cable. Featuring SmartScan™ technology, with voltage, pan size recognition, choice of power or temperature mode, ferrous pan recognition, large, LED power/temp display, plus all the features listed below.

### Construction & Performance Features:

- Sealed induction base with flanged cooking surface, for easy drop-in mounting
- Separate control panel with 43" (1.1 m) cable for easy mounting
- Rugged 5 mm thick, easy to clean, tempered, smoke-black glass cook top
- Mounting Frame Bracket
- 100% Silicon rubber protective top seal
- 110-Volt model has 1800-watts of power, the Industry's Highest
- Choice of cooking to: Power Level 1-20 or temperature settings of 110° - 400°
- 6' Power cord with standard plug (US Models)

- **SM-181R (110-120 Volt/US)**
- **SM-261R (208-240 Volt/US)**
- **SM-263R (220-240 Volt/International)**
- **SM-263RU (220-240 Volt/UK)**

### Simple, Solid State Controls With:

- Power ON/OFF Heavy Duty, Knurled Knob
- Power ON/Pan Present Indicator Lights
- Simple Knob-Set Thermostat Control
- Digital LED Display Of:
  - Power Level from 1-20 [Cook Mode]
  - Temperature: 110° - 400° F [Temp Mode] (43°C - 204°C)
- Cook/Temp Mode Touch Pad
- Over/Under Voltage Protection Standard
- Tempered, Smoke Black Glass Control Panel Overlay

### Standard Warranty:

- One Year, Parts & Labor

### Agency Listings:

- FCC
- ETL
- ETL-Sanitation to NSF-4
- CETL

### Available Accessories/Alternate Configurations:

- Universal flush mounting flange/adaptor plate [PN: AP1826] (For installation without routing solid surface material)
- Induction-Ready Pans [Spring USA Catalog]
- AF350 Under-Counter Air Filter Ranges [See Spec.SIR-7]
- Built-In, (Hold-Only) Induction Ranges [See Spec.SIR-3]
- Countertop, Portable Induction Ranges [See Spec.SIR-1]
- Countertop (Hold-Only) Induction Hot Plate [Spec.SIR-2]
- Mobile & Custom Configurations [Contact Spring USA]



## Built-In Induction Range

### Model:

- SM-181R (110 Volt/US)
- SM-261R (208-240 Volt/US)
- SM-263R (220-240 Volt/Int'l)
- SM-263RU (220/240 Volt/UK)

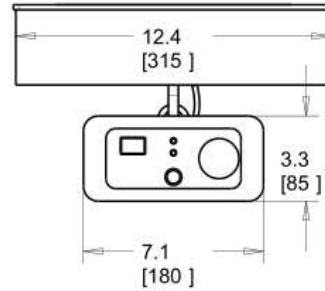
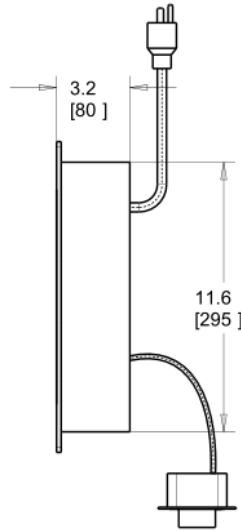
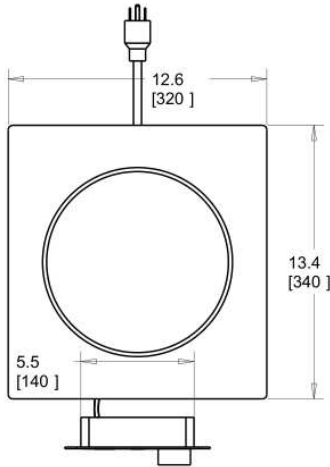

Range Glass Cut Out  
13.5" L x 12.625" W  
342 mm L x 322 mm W

Control Panel Cutout  
5.75" L x 2.71" W  
146 mm L x 69 mm W

### [EC] Electric Requirements:

Model	Voltage	Phase	Hertz	Watts	Amps	Plug
SM-181R	110-120	1	50-60	1800	15	NEMA 5-15P
SM-261R	208-240	1	50-60	2600	11.8	NEMA 6-20P
SM-263R	220-240	1	50-60	2600	10.8	CEE 7/7 16 A Schuko Plug
SM-263RU	220-240	1	50-60	2600	10.8	BS 1363 13 A UK Plug

### Key Dimensions & Shipping Information:

Model	Unit Width	Unit Length	Unit Height	Shipping Weight *	Single Unit Shipping Carton *		
					Width	Length	Height
SM-181R	12.6"	13.4"	3.20"	13 lbs.	15-1/2"	18"	4-1/2"
SM-261R	12.6"	13.4"	3.20"	13 lbs.	16"	19-1/2"	5-1/2"
SM-263R	320 mm	340 mm	80 mm	5.8 kg.	406 mm	495 mm	140 mm
SM-263RU	320 mm	340 mm	80 mm	5.8 kg	406 mm	495 mm	140 mm

\* SM-181R Two Unit Case Pack: Weight = 29 lbs. (13.1 kg); Length = 22" (559 mm); Width = 19" (483 mm); Height = 16" (406 mm)

\* SM-261& 3R(U) Two Unit Case Pack: Weight = 33 lbs. (14.9 kg); Length = 25" (635 mm); Width = 23" (584 mm); Height = 18" (457 mm)

### Notes & Conditions:

This induction range must be flush mounted (by others) in a heat resistant countertop 2" (51 mm thick maximum) or base cabinet with the control module mounted vertically on the front of that enclosure [See cutout dimensions above]. For optimum performance, allow 4" (102 mm) clearance from front and sides; and 7" (178 mm) below unit for good air circulation. **Cabinet ventilation must be provided.** The inside temperature of the cabinet must not exceed 90°F / 32°C. Actual range temperature may vary due to a number of variables, such as ambient temperature in the immediate surrounding area, content and volume of food being heated or cooked, and whether or not you are using a lid on the serving vessel. For maintenance instructions, refer to your Installation & Operation Manual.

This induction range requires use of ferrous metal, induction-ready cookware.

