



Model SM-651R



Built-In (Hold-Only) Induction Warmer

Order Guide:

✓	Model Number	Voltage	Peak Power	Plug Type
	SM-651R (US)	110-120	650 Watts	NEMA 5-15
	SM-653R (Int'l)	220-240	650 Watts	CEE7/7 Schuko Plug
	SM-653RU	220-240	650 Watts	BS1363 UK Plug

Short Form Specification:

Unit to be a Spring USA *MAX Induction™* SM-____ (Specify 651R, 653R or 653RU) Model, Built-In, Flush Mountable (Hold-Only) Induction Heating Unit, with installation-ready modular flanged base with 5 mm thick tempered glass hot top with (optional) mounting frame bracket; and separate control panel with 44" (1.1 m) cable, providing four (4) temperature settings with a light-up temperature indicator control box; plus all the features listed.

Construction & Performance Features:

- Sealed induction base with flanged cooking surface, for easy drop-in mounting
- Separate control panel with 44" (1.1 m) cable for easy front mounting
- Rugged 5 mm thick, easy to clean tempered glass cook top
- Mounting Frame Bracket
- 100% Silicon rubber protective top seal
- Energy saving 650-watt model for product holding (**Hold Only**)
- Choice of four (4) hold temperature settings
- 5' (1.52 m) Power cord with standard plug

- SM-651R (110-120 Volt/US)
- SM-653R (220-240 Volt/International)
- SM-653RU (220-240 Volt/UK)

Simple, Solid State Controls With:

- Power ON/OFF Touch Pad
- Power ON/Pan-Present Indicator Lights
- Four-Position Set-Hold Temperature Control
- Lighted Temperature Indicator

Low	Low-Med	Med-High	High
145 - 155° F	156 - 165° F	166 - 175° F	176 - 185° F
61 - 71° C	72 - 76° C	77 - 82° C	83 - 87° C

- Over/Under Voltage Protection Standard
- Tempered, Black Glass Control Panel Overlay

Standard Warranty:

- One Year, Parts & Labor

Agency Listings:

- FCC
- ETL
- ETL-Sanitation to NSF-4
- CETL

Available Accessories/Alternate Configurations:

- Universal flush mounting flange/adaptor plate [PN: P1826] (For installation without routing solid surface material)
- Induction-Ready Pans [Spring USA Catalog]
- AF350 Under-Counter Air Filter Ranges [See Spec.SIR-7]
- Built-In, High Power Induction Ranges [See Spec.SIR-3]
- Countertop, Portable Induction Ranges [See Spec.SIR-1]
- Countertop (Hold-Only) Induction Hot Plate [Spec.SIR-2]
- Mobile & Custom Configurations [Contact Spring USA]



Project: _____

Item #: _____ Quantity: _____

Model #: _____



Built-In (Hold-Only) Induction Warmer:

Model: SM-651R (110-Volt/US)
SM-653R (220-240 Volt/Int'l)
SM-653RU (220-240 Volt/UK)

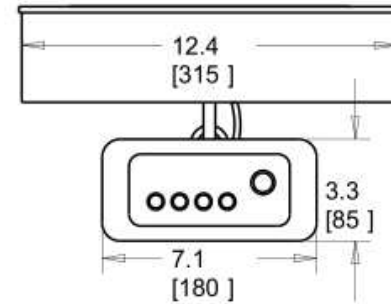
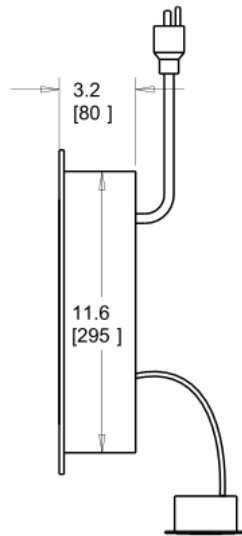
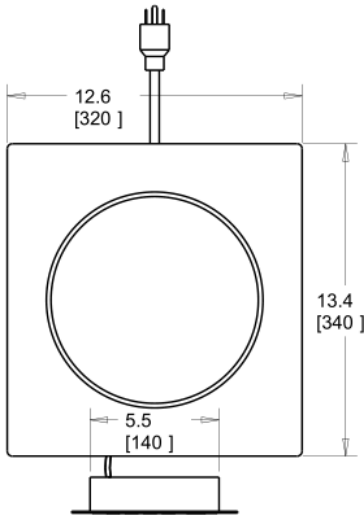

Range Cut Out
 13.5" L x 12.625" W
 342 mm L x 322 mm W

Control Panel Cutout
 5.75" L x 2.71" W
 146 mm L x 69 mm W

[EC] Electric Requirements:

Model	Voltage	Phase	Hertz	Watts	Amps	Plug
SM-651R	110-120	1	50-60	650	5.4	NEMA 5-15P
SM-653R	220-240	1	50-60	650	2.7	CEE 7/7 Schuko Plug
SM-653RU	220-240	1	50-60	650	2.7	BS1363 UK Plug

Key Dimensions & Shipping Information:

Model	Unit Width	Unit Length	Unit Height	Weight *	Single Unit Shipping Carton *		
					Width	Depth	Height
SM-651R	12.6"	13.4	3.20	Unit: 11 lbs (5 kg)	18"	17"	7"
SM-653R	320 mm	340 mm	80 mm	*Shipping: 13 lbs.	457 mm	432 mm	178 mm
SM-653RU	320 mm	340 mm	80 mm	(5.8 kg)			

* Two Unit Case Pack: Weight = 29 lbs. (13.1 kg); Length = 22" (559 mm); Width = 19" (483 mm); Height = 15" (381 mm)

Notes & Conditions:

This induction range must be flush mounted (by others) in a heat resistant countertop (2"/51 mm thick maximum) or base cabinet with the control module mounted vertically on the front of that enclosure [See cutout dimensions above]. For optimum performance, allow 4" (102 mm) clearance from front and sides; and 7" (178 mm) below unit for good air circulation. **Cabinet ventilation must be provided.** The inside temperature of the cabinet must not exceed 90°F / 32°C. Actual range temperature may vary due to a number of variables, such as ambient temperature in the immediate surrounding area, content and volume of food being heated or cooked, and whether or not you are using a lid on the serving vessel.

This induction range requires use of ferrous metal, induction-ready cookware.

Due to continuous product improvement, specifications are subject to change without notice